

02

PLAN VIEW

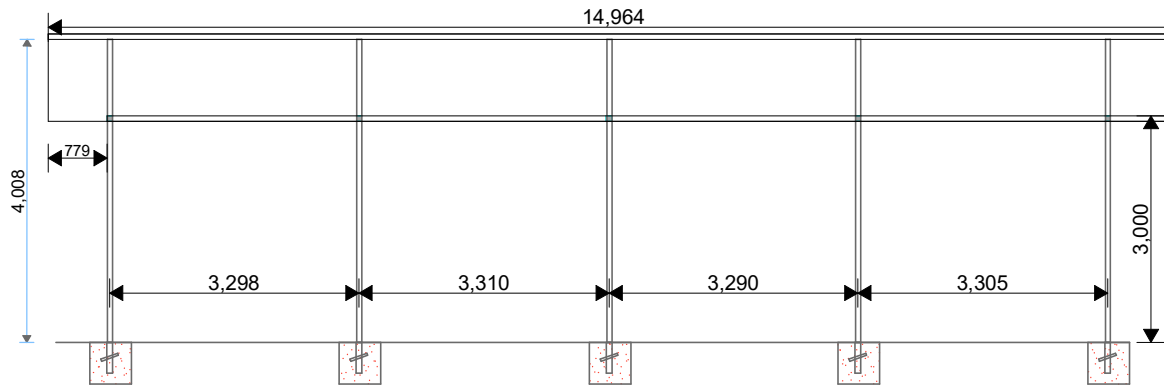

ELEVATION 01

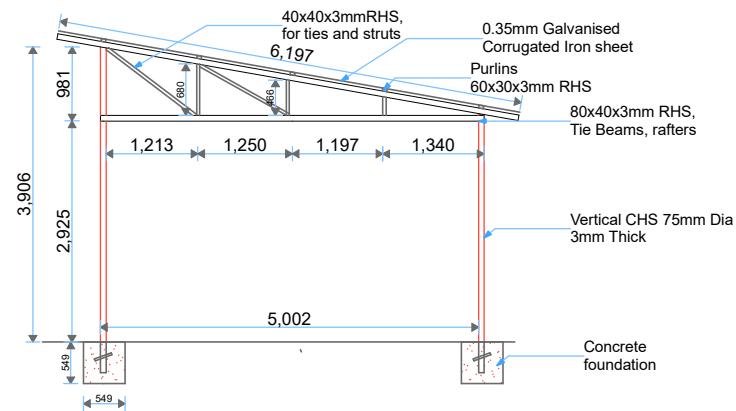

ELEVATION 02

NOTES

1. All dimensions in mm unless specified otherwise
2. All steel metal surfaces to be painted with antirust prime coat before installation
3. A minimum of strength of class 25 concrete to be used for the foundation.
4. All welding joint thickness to be checked and approved by the Engineer



PROJECT:

Car Park Yard

LOCATION:

UNHCR SO, EL-FASHER

DRAWING

Plan, Elevations

DRAWN BY

Gabriel Masika

DATE:

07.09.2020

DRAWING NO.

ELF-2020-004

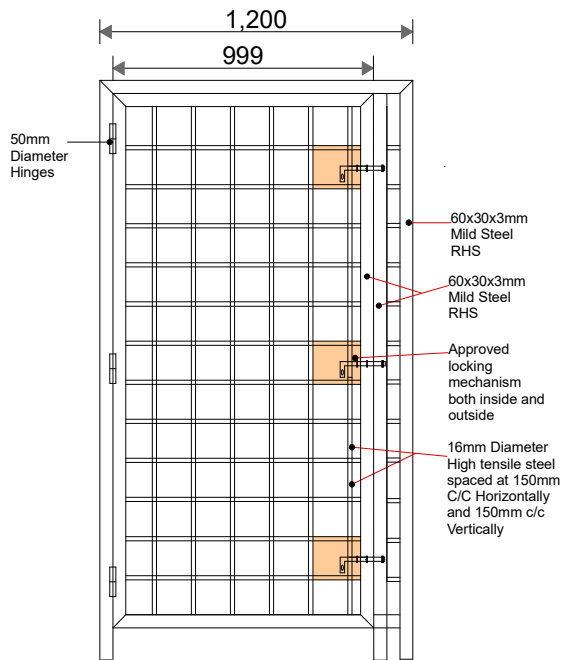

DOOR GRILL 01

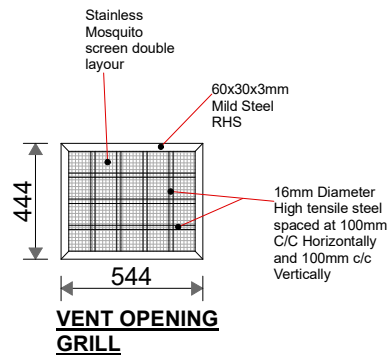

VENT OPENING GRILL

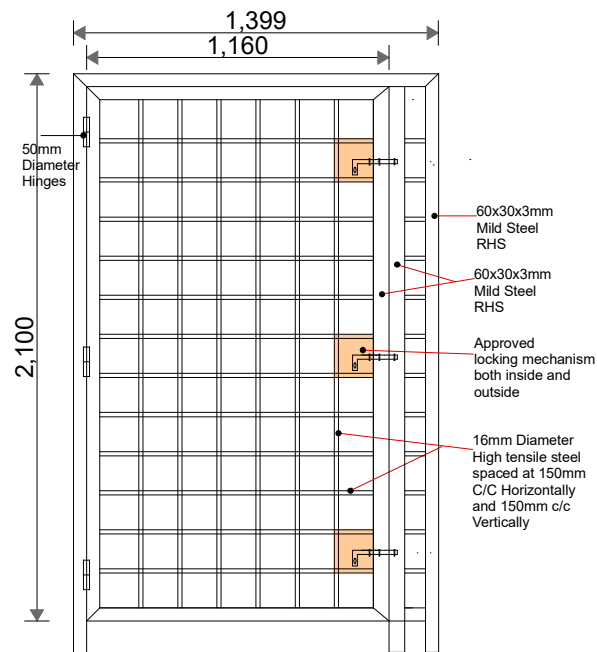

DOOR GRILL 03

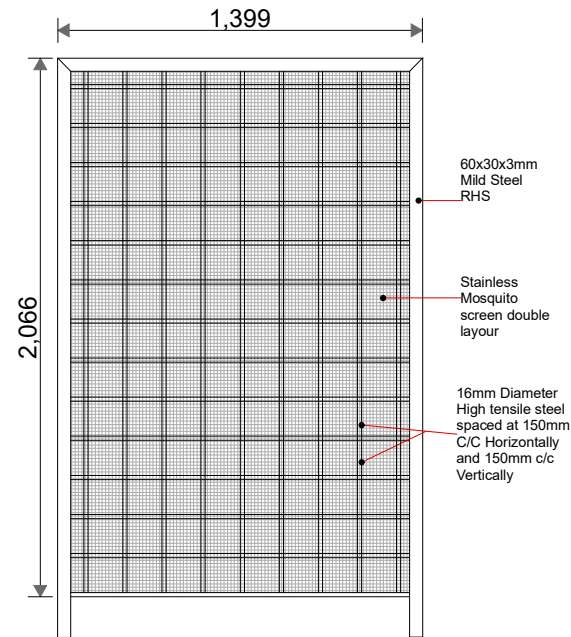

DOOR GRILL 02

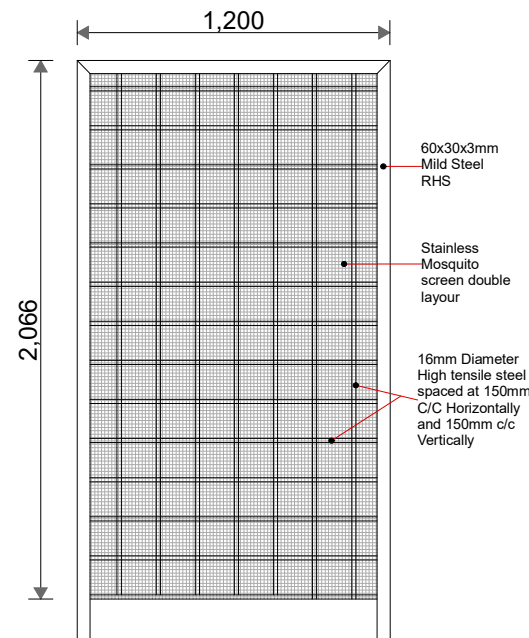

DOOR GRILL 04

NOTES

1. All dimensions in mm unless specified otherwise
2. All steel metal surfaces to be painted with antirust prime coat before installation
3. A minimum of strength of class 25 concrete to be used for the foundation.
4. All welding joint thickness to be checked and approved by the Engineer



PROJECT:

GRILLS

LOCATION:

EL-FASHER, ND

DRAWING

Elevations

DRAWN BY

Gabriel Masika

DATE:

22.09.2020

DRAWING NO.

ELF-2020-006

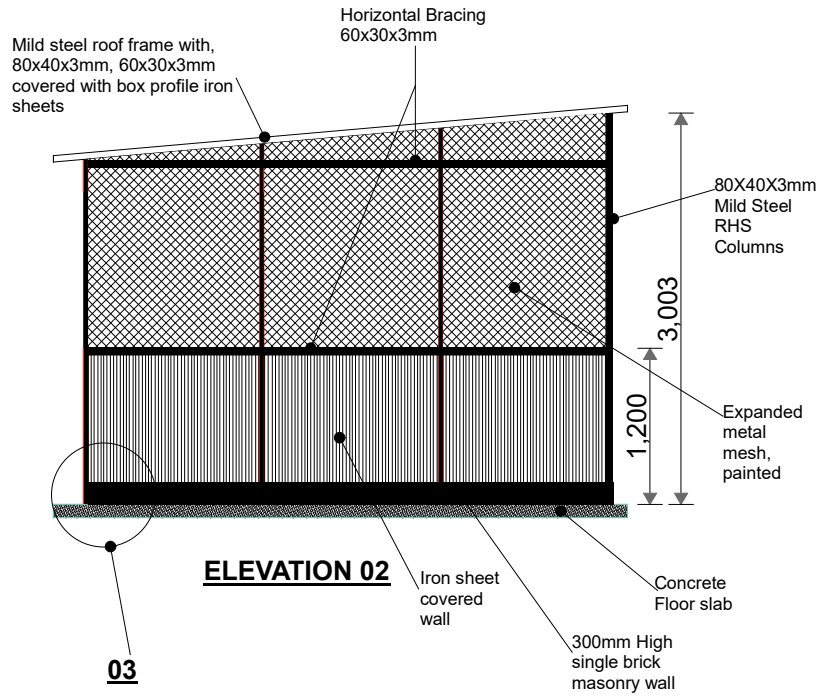
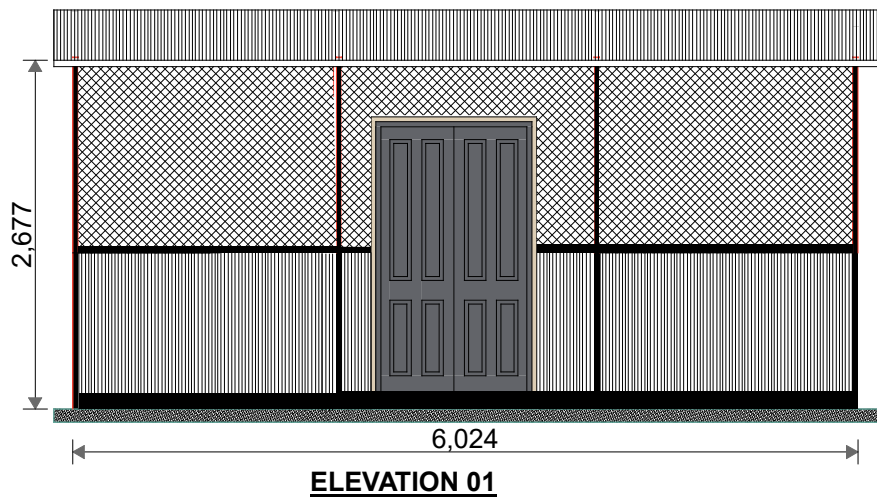

03

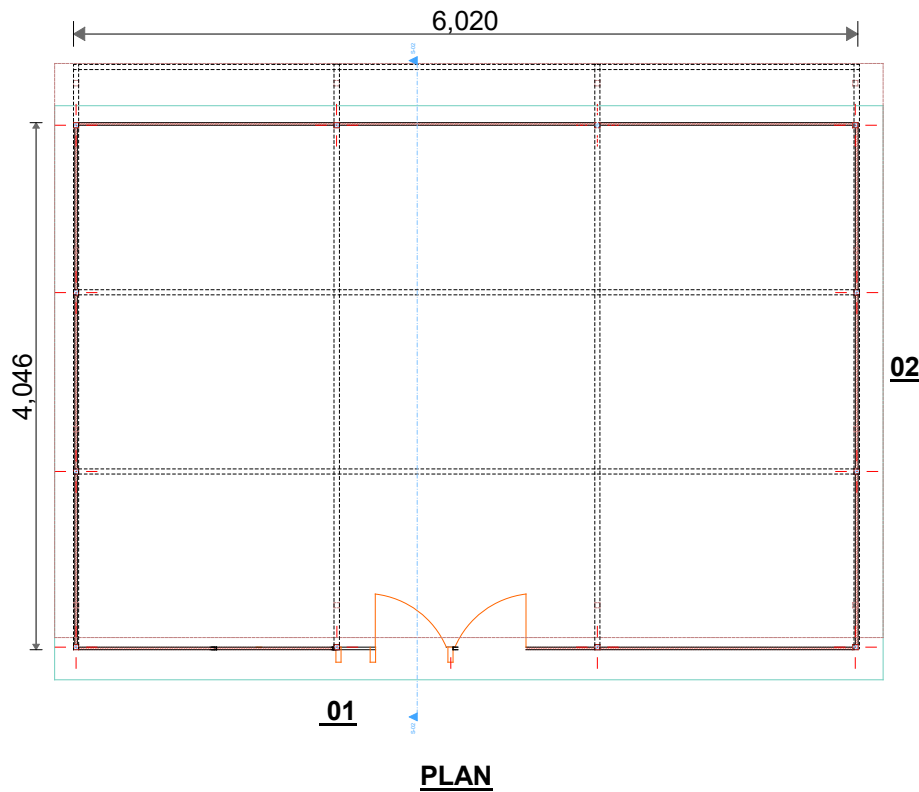

02

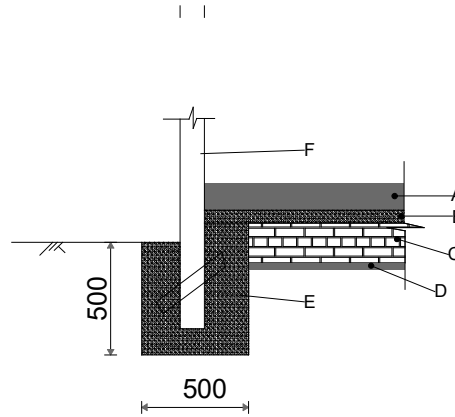

- A: 300mm single layer brick masonry wall plastered on outside as a plint
- B: 100mm Plain concrete cast as ground slab on top of select material fill
- C: 300mm Strip masonry foundation
- D: 50mm Plain concrete laid in foundatio trenches
- E: Plain concrete class 20 poured around the vertical MS columns
- F: Vertical poles 80x40x3mm RHS

- NOTES**
1. All dimensions in mm unless specified otherwise
 2. All steel metal surfaces to be painted with antirust prime coat before installation
 3. A minimum of strength of class 25 concrete to used for the foundation.
 4. All welding joint thickness to be checked and approved by the Engineer



PROJECT:
GENERATOR SHED

LOCATION:
SO, EL-FASHER

DRAWING
Plan, Elevations

DRAWN BY
Gabriel Masika

DATE:
22.09.2020

DRAWING NO.
ELF-2020-007

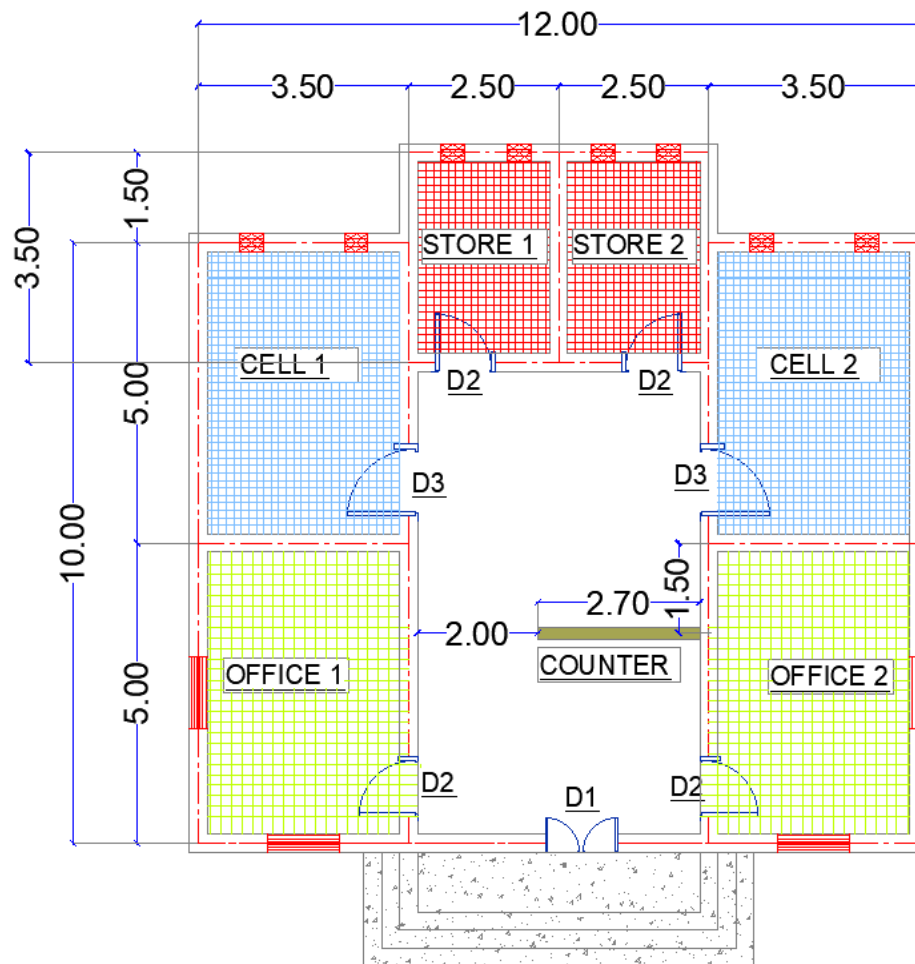

PLAN LAYOUT Police Post

Scale 1:100 A3



FINISHING SCHEDULE

1	
2	
3	
1	
2	
3	
4	
1	

ELECTRICAL KEY

S	Description

UNHCR

MODEL (A) May 2020

Design By: **A1**

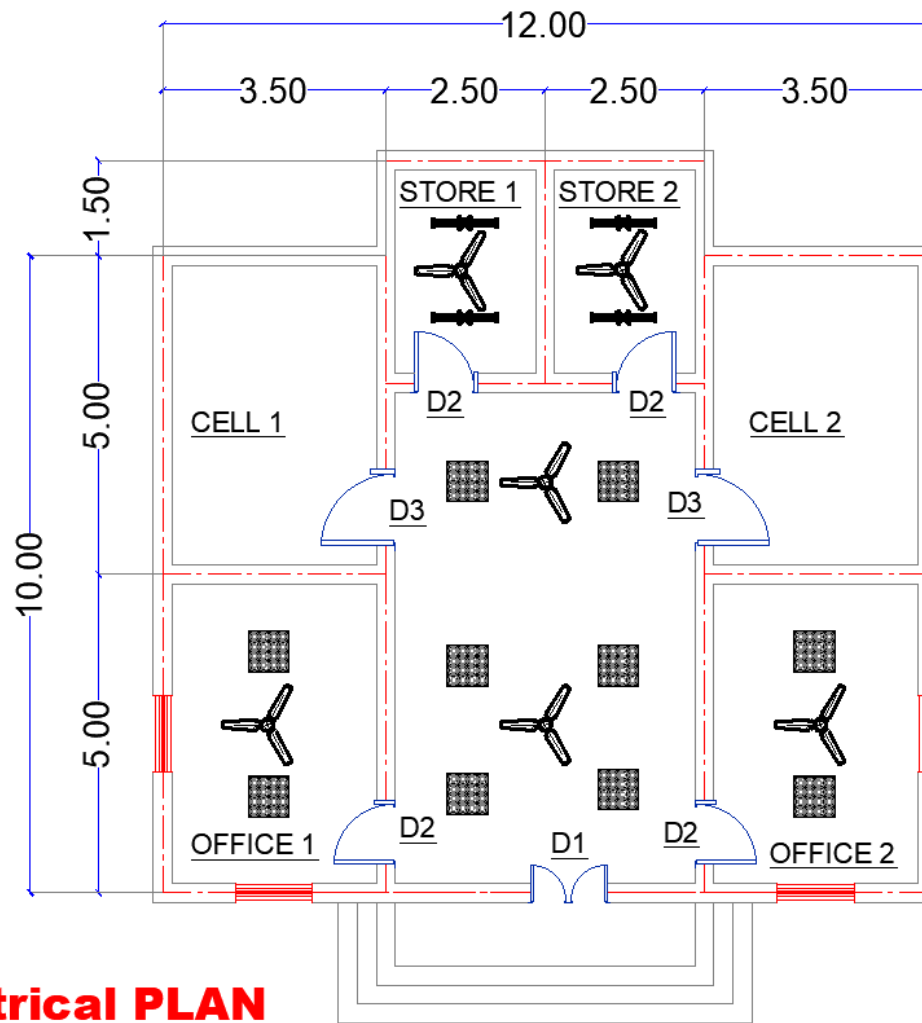

Electrical PLAN

Police Post

Scale 1:100 A3



FINISHING SCHEDULE

1	
2	
3	
1	
2	
3	
4	
1	

ELECTRICAL KEY

S	Description

UNHCR

MODEL (A) May 2020

Design By: **A1**

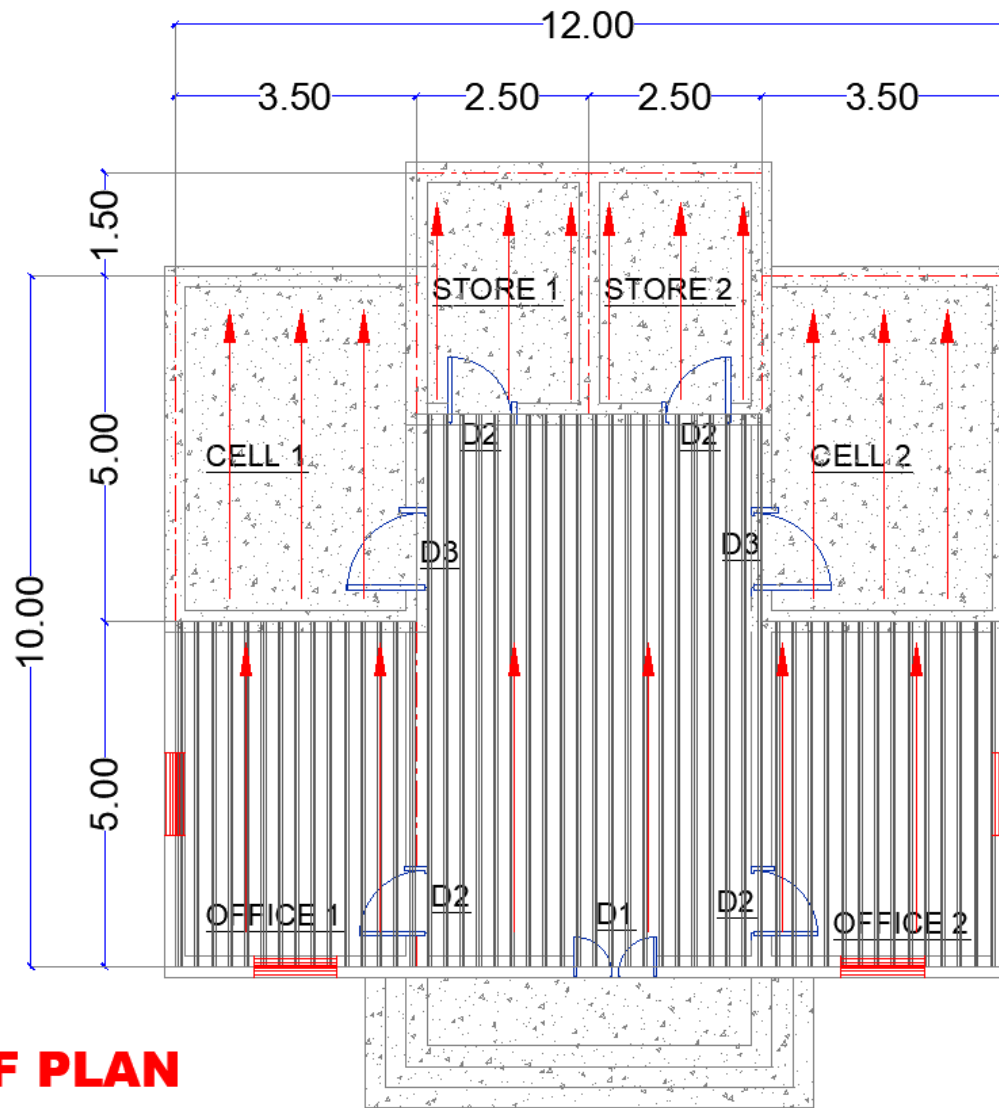

ROOF PLAN Police Post

Scale 1:100 A3



FINISHING SCHEDULE

1	
2	
3	
1	
2	
3	
4	
1	

ELECTRICAL KEY

S	Description

UNHCR

MODEL (A) May 2020

Design By: **A1**

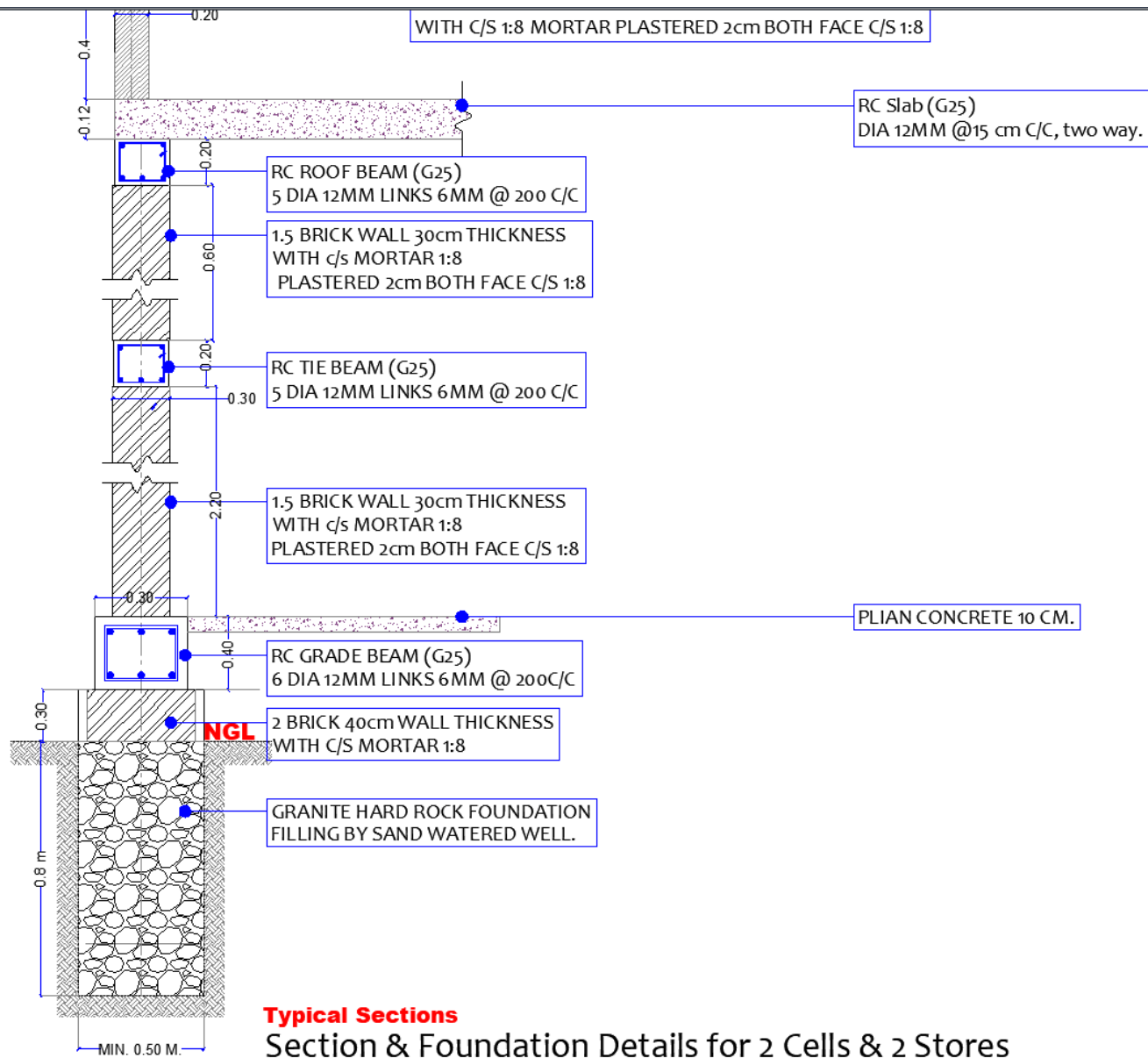

Typical Sections
Section & Foundation Details for 2 Cells & 2 Stores



FINISHING SCHEDULE

1	
2	
3	
1	
2	
3	
4	
1	

ELECTRICAL KEY

S	Description

UNHCR

MODEL (A) May 2020

Design By: **A1**

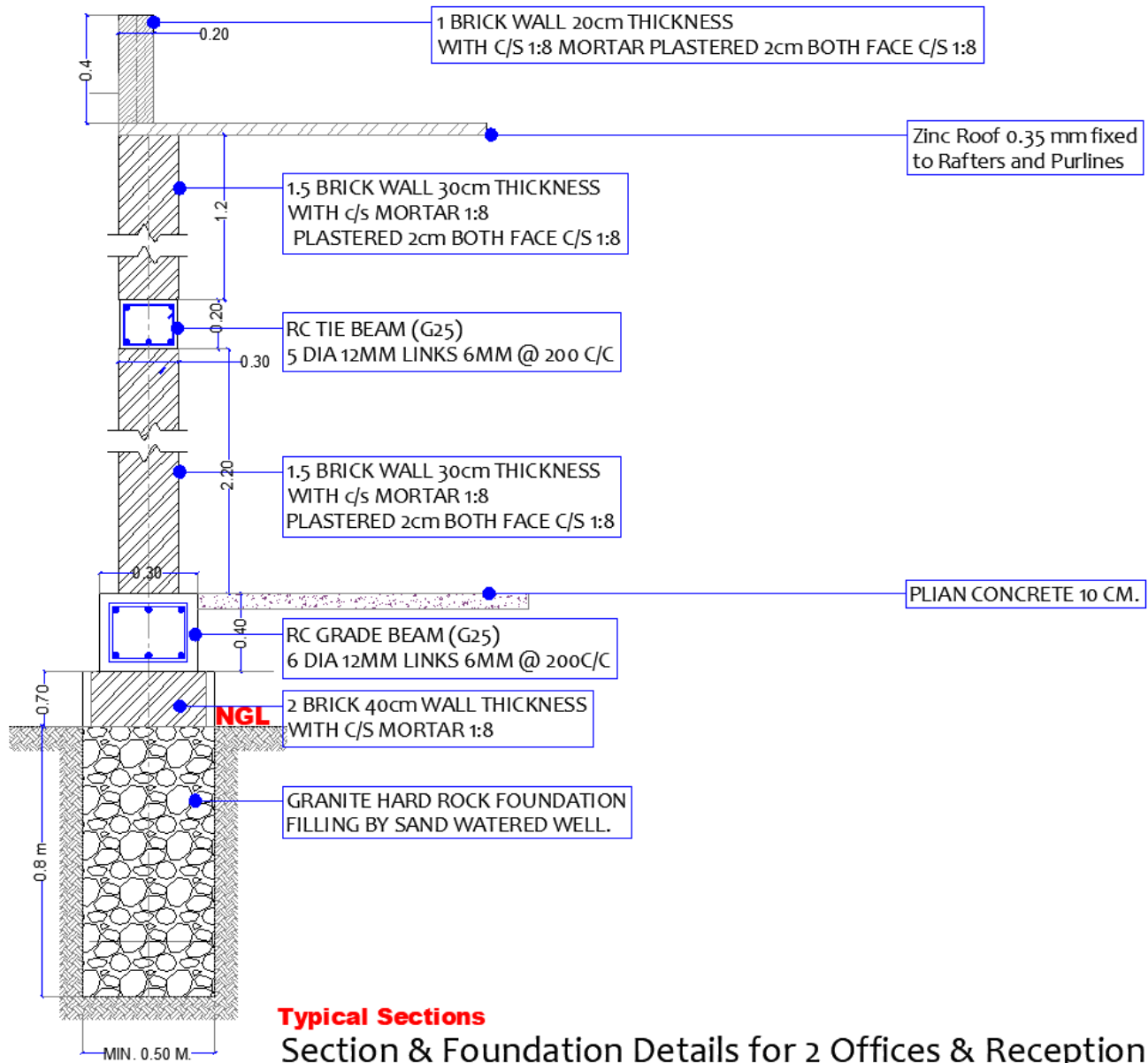

Typical Sections

Section & Foundation Details for 2 Offices & Reception

Scale: NT5A3



FINISHING SCHEDULE

1
2
3
1
2
3
4
1

ELECTRICAL KEY

S	Description

UNHCR

MODEL (A) May 2020

Design By:

A1

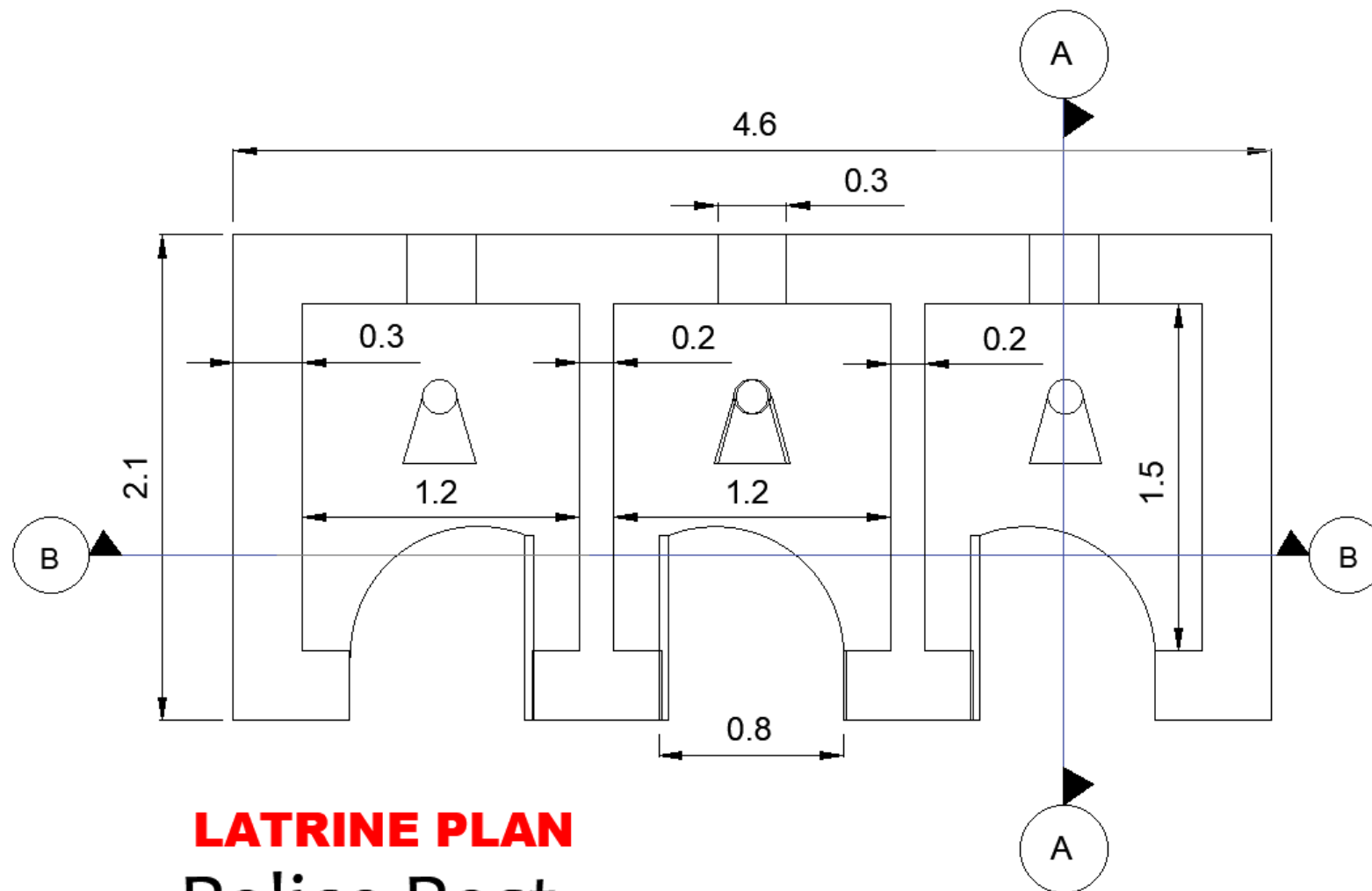

LATRINE PLAN Police Post

Scale 1:100 A3

FINISHING SCHEDULE

1
2
3
1
2
3
4
1

ELECTRICAL KEY

S	Description

UNHCR

MODEL (A) May 2020

Design By: **A1**

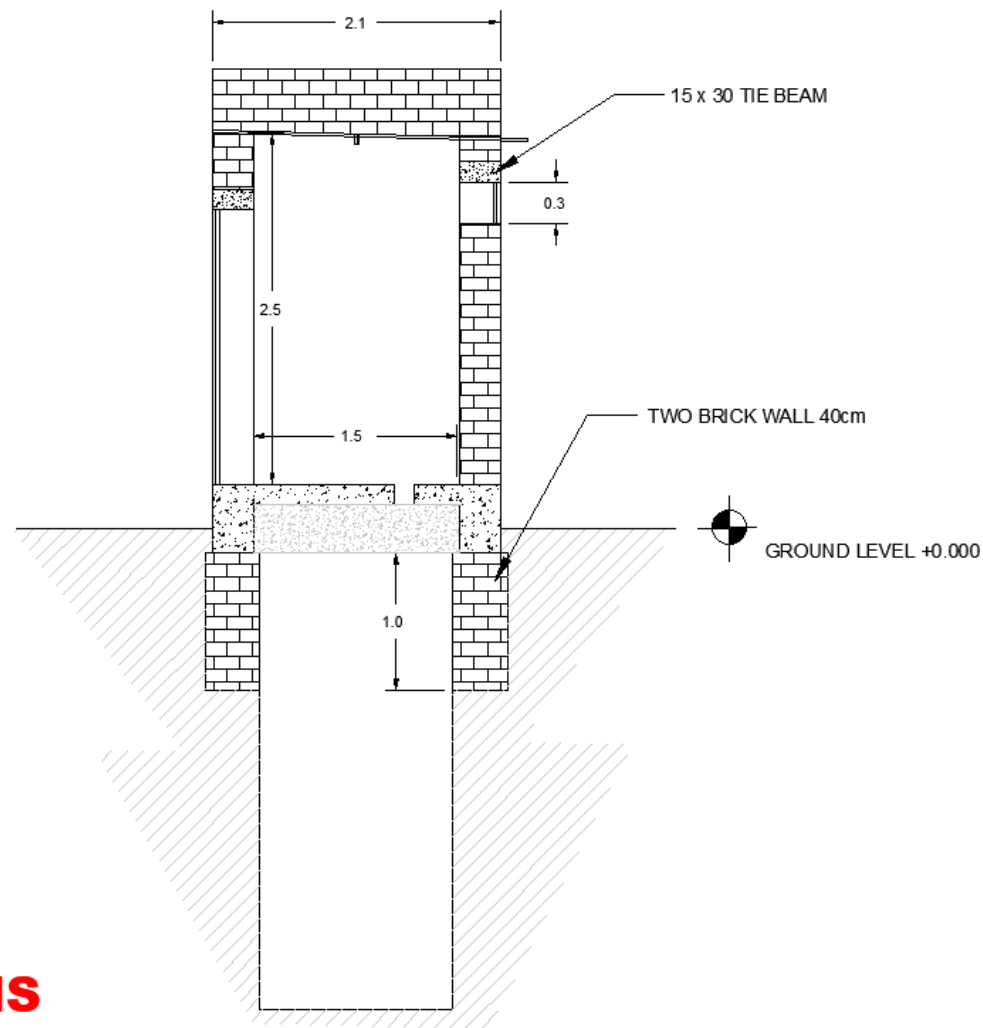

FINISHING SCHEDULE

1	
2	
3	
1	
2	
3	
4	
1	

ELECTRICAL KEY

<i>S</i>	<i>Description</i>

UNHCR

LATRINE SECTIONS
Police Post

Scale 1:100 A3

LATRINE SECTION A-A

MODEL (A) May 2020

Design By: **A1**

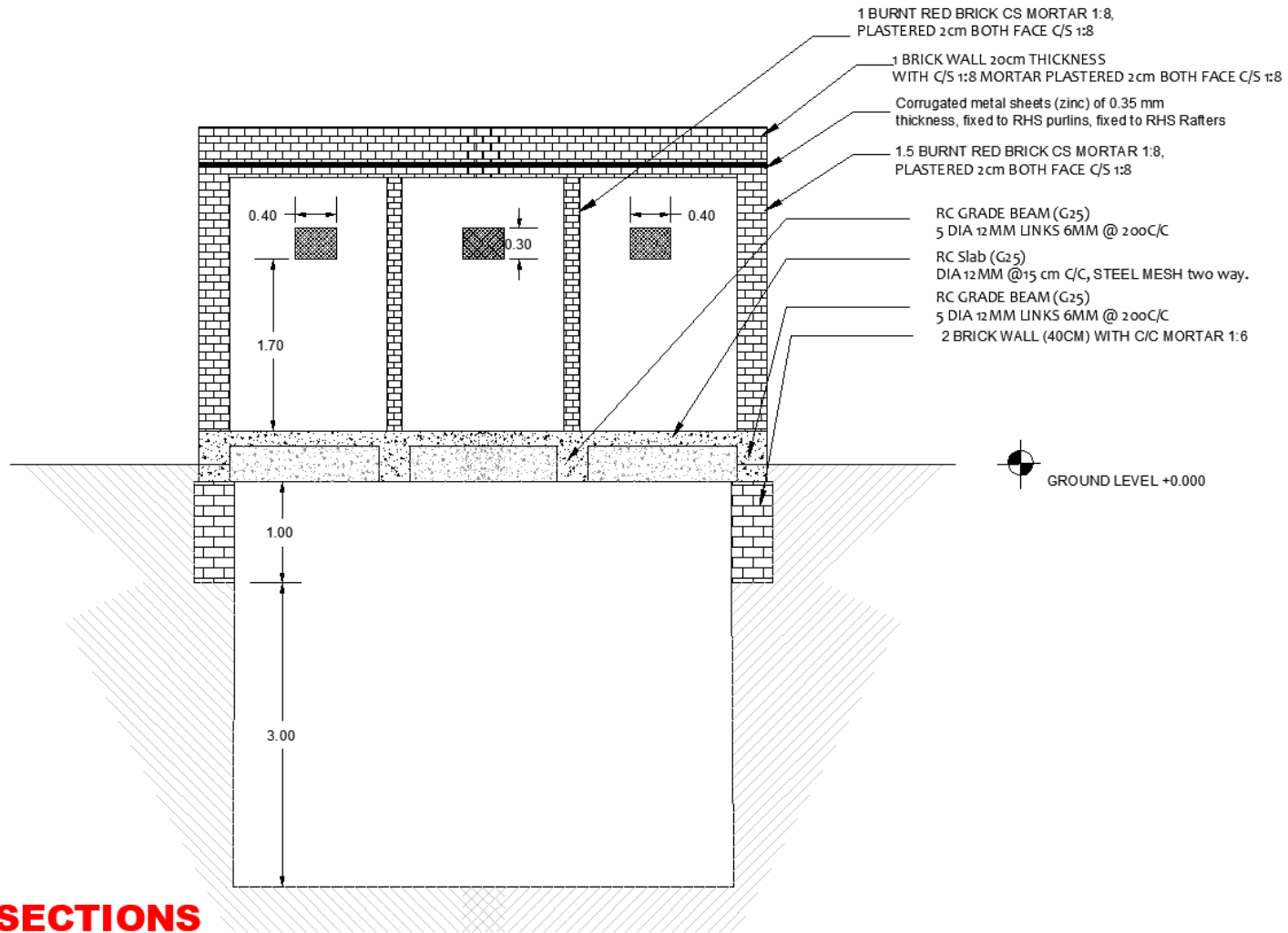

FINISHING SCHEDULE

1	
2	
3	
1	
2	
3	
4	
1	

ELECTRICAL KEY

<i>Sl</i>	<i>Description</i>

UNHCR

LATRINE SECTIONS
Police Post

Scale 1:100 A3

LATRINE SECTION B-B

MODEL (A) May 2020

Design By:

A1

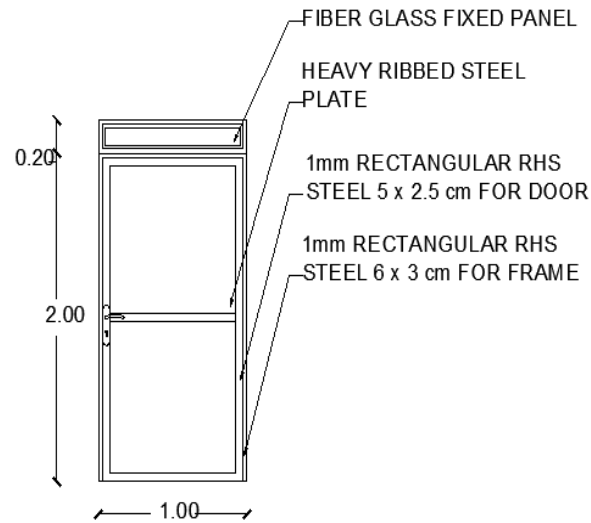

OFFICE DOOR
D2

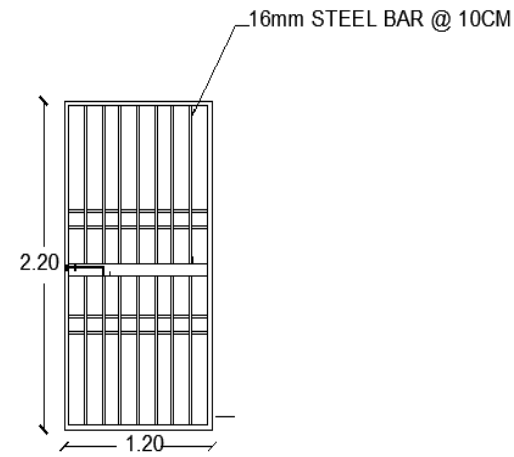

CELL DOOR
D3

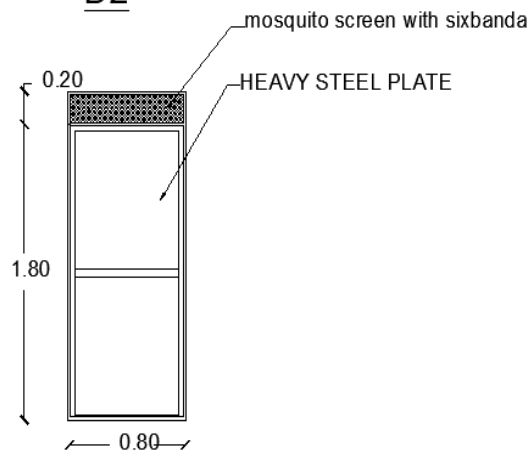

LATRINE DOOR
D4

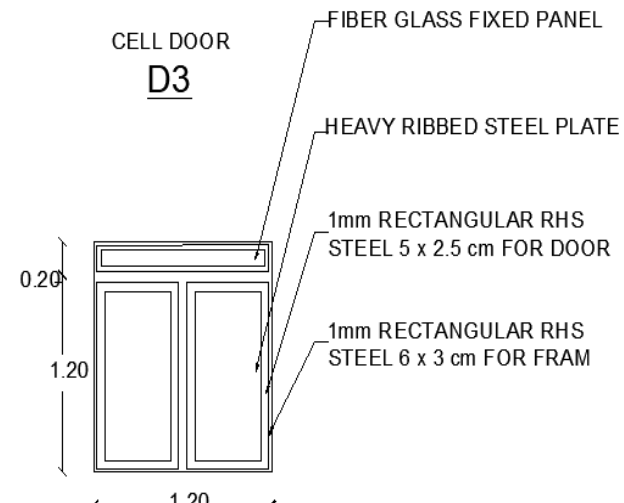

OFFICE WINDOW

W1

DOOR & WINDOWS

Police Post

Scale 1:100 A3

FINISHING SCHEDULE

1
2
3
1
2
3
4
1

ELECTRICAL KEY

S	Description

UNHCR

MODEL (A)

May
2020

Design By:

A1

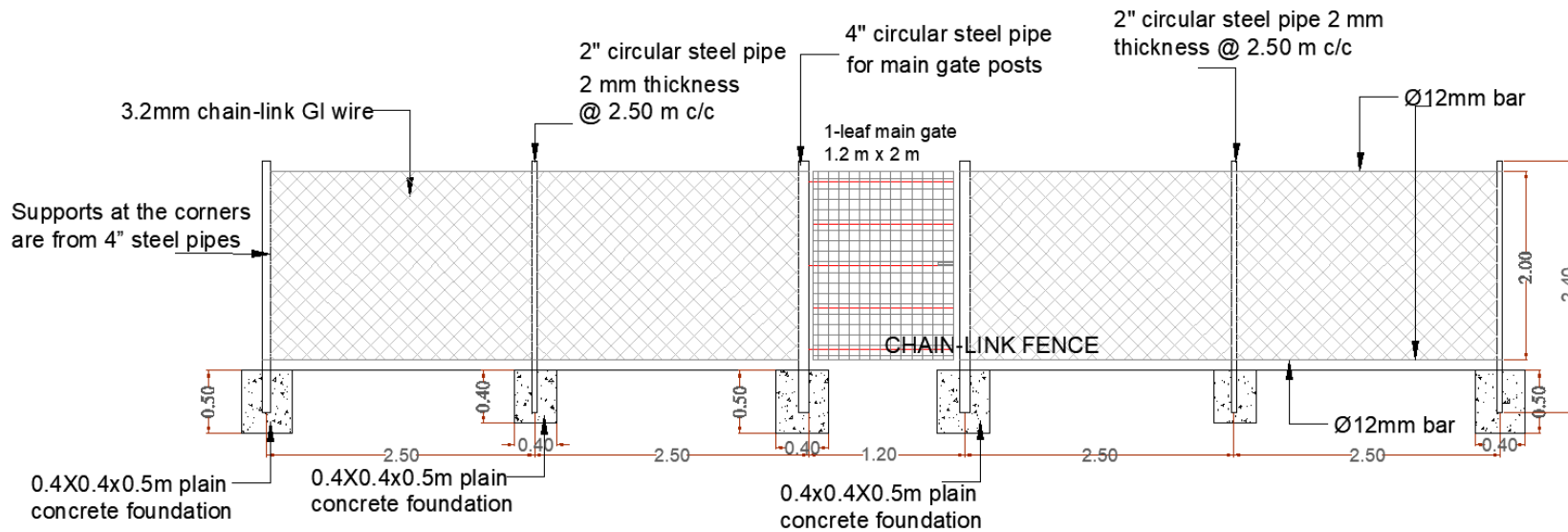

Chain Link Fence Police Post

Scale 1:100 A3

FINISHING SCHEDULE

1
2
3
1
2
3
4
1

ELECTRICAL KEY

S	Description

UNHCR

MODEL (A) May 2020

Design By: **A1**

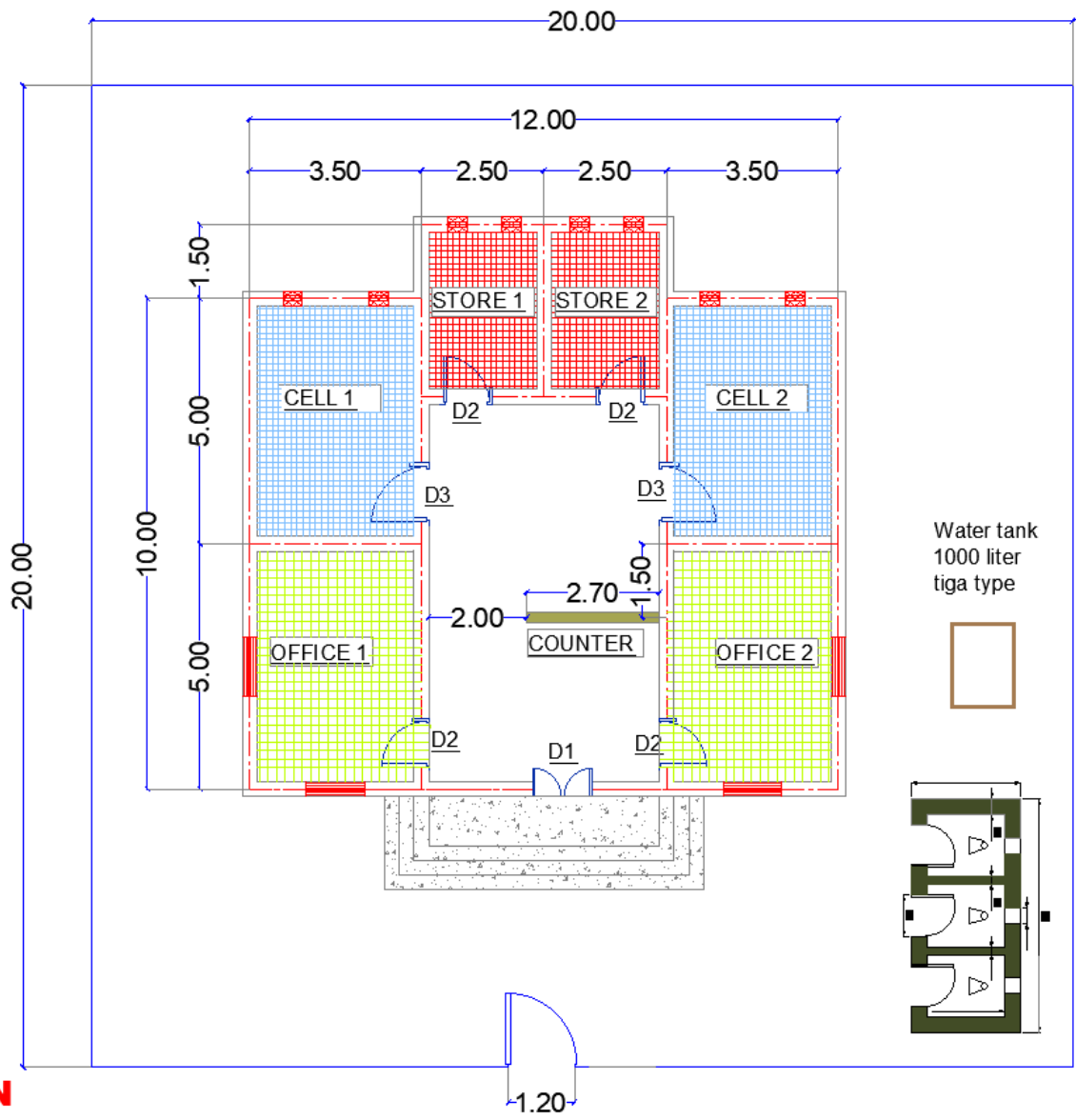

FINISHING SCHEDULE

1	
2	
3	
1	
2	
3	
4	
1	

ELECTRICAL KEY

<i>S</i>	<i>Description</i>

UNHCR

GENERAL PLAN
Police Post

Scale 1:100 A3

MODEL (A) May 2020

Design By: **A1**

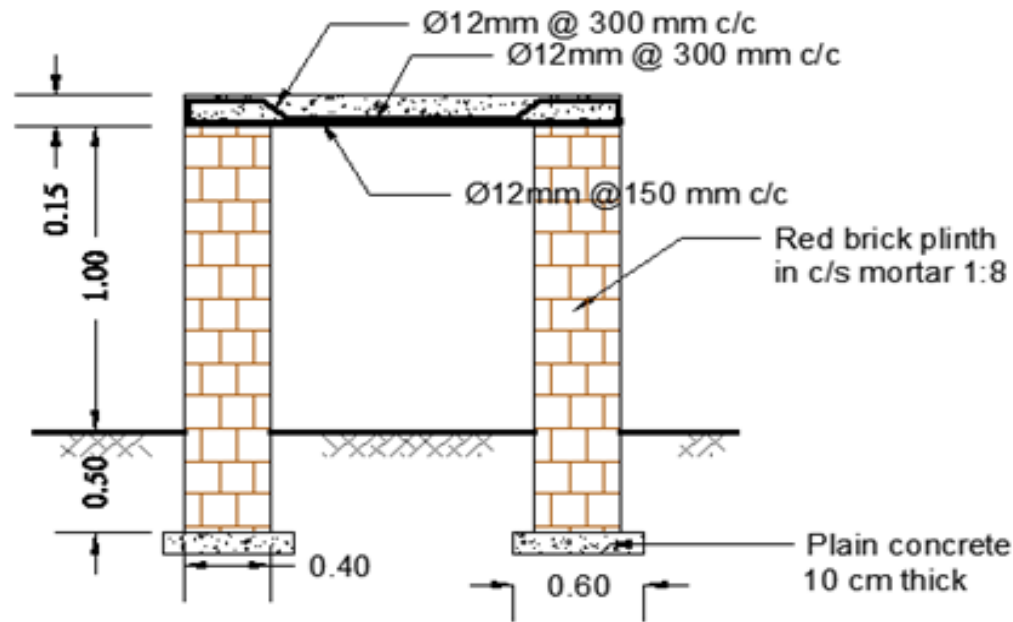

SECTION B-B

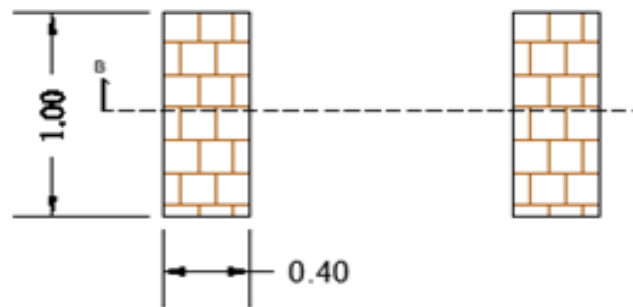

PLAN

PLASTIC TANK PLINTH AT
NEAR TOILETS

FINISHING SCHEDULE

1	
2	
3	
1	
2	
3	
4	
1	

ELECTRICAL KEY

S	Description

UNHCR

MODEL (A) May 2020

Design By: **A1**